

CNMG / Turning

Negative insert / rhomb 80°

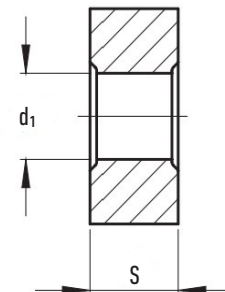
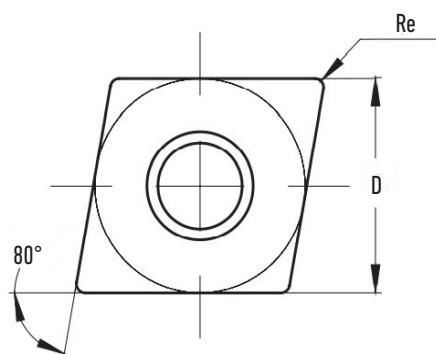

Code	Dimensions					Cutting conditions					
	D	S	Re	d ₁	A _p	A _{pmin.}	A _{pmax.}	F _z	F _{zmin.}	F _{zmax.}	
	(mm)					Chip depth (mm)			Feed (mm/t)		
CNMG120408M	● ○	12,700	4,76	0,80	5,16	3,00	0,50	5,50	0,30	0,15	0,50
CNMG120412M	● ○	12,700	4,76	1,20	5,16	3,00	0,80	5,50	0,35	0,18	0,60